

A Fully-Implantable Wireless System for Human Brain-Machine Interfaces Using Brain Surface Electrodes: W-HERBS

Masayuki HIRATA^{†a)}, Kojiro MATSUSHITA[†], Takafumi SUZUKI^{††}, *Nonmembers*,
Takeshi YOSHIDA^{†††}, *Member*, Fumihiko SATO^{††††}, Shayne MORRIS[†], Takafumi YANAGISAWA[†],
Tetsu GOTO[†], *Nonmembers*, Mitsuo KAWATO^{†††††}, *Fellow*, and Toshiki YOSHIMINE[†], *Nonmember*

SUMMARY The brain-machine interface (BMI) is a new method for man-machine interface, which enables us to control machines and to communicate with others, without input devices but directly using brain signals. Previously, we successfully developed a real time control system for operating a robot arm using brain-machine interfaces based on the brain surface electrodes, with the purpose of restoring motor and communication functions in severely disabled people such as amyotrophic lateral sclerosis patients. A fully-implantable wireless system is indispensable for the clinical application of invasive BMI in order to reduce the risk of infection. This system includes many new technologies such as two 64-channel integrated analog amplifier chips, a Bluetooth wireless data transfer circuit, a wirelessly rechargeable battery, 3 dimensional tissue-fitting high density electrodes, a titanium head casing, and a fluorine polymer body casing. This paper describes key features of the first prototype of the BMI system for clinical application.

key words: brain-machine interface, implantable device, wireless, brain surface electrodes, motor restoration

1. Introduction

1.1 General Backgrounds

The brain-machine interface (BMI) is a new method for man-machine interface, which enables us to control machines and communicate with others without input devices but directly using brain signals alone (Fig. 1). There are many diseases and conditions that lead to a loss of muscular control without disruption of the patients' cognitive abilities. These include amyotrophic lateral sclerosis (ALS), brainstem stroke, spinal cord injury, muscular dystrophy, Parkinson's disease and cerebral palsy, etc. BMI technology can offer these patients greater independence and a higher quality of life by enabling the control of external devices to

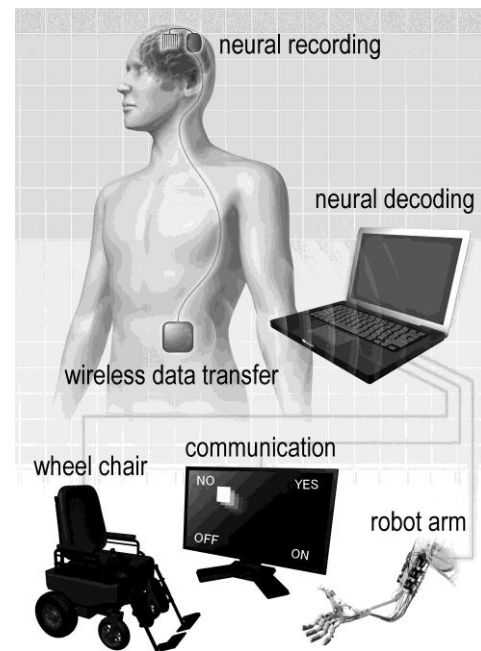

Fig. 1 A conceptual diagram of the brain machine interface.

communicate with others and to manipulate their environment according to their will [1]. Functional restoration using BMI is a more feasible solution in the shorter term when compared to methods using neural regeneration or neural transplantation, which presently lack the critical technologies necessary to organize functional neural networks.

There are two types of BMI. These are invasive BMI and non-invasive BMI. Invasive BMI requires surgical procedures and measures brain signals from intracranial electrodes (needle electrodes or brain surface electrodes), while non-invasive BMI measures brain signals non-invasively from outside of the body using scalp electrodes etc. To achieve higher performance and thus usefulness, we use invasive BMI techniques which involve the implantation of devices. For use in a practical situation, invasive BMI needs organic integration of the following medical and engineering technologies.

- 1) Neural recording with high spatiotemporal resolution
- 2) High speed transfer and processing of neural signals
- 3) Optimal extraction of neurophysiological features

Manuscript received April 19, 2011.

Manuscript revised May 10, 2011.

[†]The authors are with the Department of Neurosurgery, Osaka University, Medical School, Suita-shi, 565-0871 Japan.

^{††}The author is with the Graduate School of Information Science and Technology, The University of Tokyo, Tokyo, 113-0033 Japan.

^{†††}The author is with the Graduate School of Advanced Sciences of Matter, Hiroshima University, Higashihiroshima-shi, 739-8530 Japan.

^{††††}The author is with Group of Electrical Engineering, Communication Engineering, Electronic Engineering, and Information Engineering, Tohoku University, Sendai-shi, 980-8578 Japan.

^{†††††}The author is with ATR Brain Information Communication Research Laboratory Group, Kyoto-fu, 619-0288 Japan.

a) E-mail: mhirata@nsurg.med.osaka-u.ac.jp

DOI: 10.1587/transcom.E94.B.2448

Table 1 Brain signals used for BMI.

	Measured physiological phenomena	Spatial resolution	Temporal resolution	Time delay	Invasiveness	Long term recording stability	Portability
fMRI	CBF	○ 3–5mm	× 4–5s	× 4–5S	◎	○	×
NIRS	CBF	× 2cm	× 4–5s	× 4–5S	◎	○	○
EEG	Neural activities	× 3–4cm	○ 1ms	◎ 0	◎	○	○
MEG	Neural activities	△ 5–10mm	◎ 0.1ms	◎ 0	◎	○	×
ECoG	Neural activities	○ 2–3mm	◎ 0.1ms	◎ 0	△	◎	◎
LFP	Neural activities	○ 1mm	◎ < 0.1ms	◎ 0	×	△	◎
spike	Neuronal activities	◎ 0.2mm	◎ < 0.1ms	◎ 0	×	×	◎

NIRS: near-infrared spectroscopy, CBF: cerebral blood flow, MEG: magnetoencephalography, LFP: local field potential

- 4) Neural decoding
- 5) Control of external devices such as robots
- 6) Downsizing, integration, and implantation of electronic devices, and the use of wireless technology.
- 7) Non-invasive evaluations for appropriate surgical indications.
- 8) On-target survey and analysis of patient needs
- 9) Addressing of neuroethical issues

1.2 Clinical Studies Using Electroocorticograms Recorded from Brain Surface Electrodes

In the process of providing neurosurgical treatments for certain groups of patients, we sometimes record brain signals (electrocorticograms: ECoGs) or electrically stimulate the brain using electrodes directly placed on the brain surface. ECoGs selectively measure brain signals within the limited distance of a few milli-meters without distortion, and is in addition, insusceptible to external noises, while scalp skin electrodes measure distorted brain signals (electroencephalograms: EEGs) from a distance of up to a few centimeters. Furthermore, ECoG recording from brain surface electrodes is stable for at least as long as one year [2], whereas spike recordings from needle electrodes gradually deteriorate in yield due to chronic inflammatory tissue reactions. ECoG is a well-balanced brain signal for BMI (Table 1). Thus, we prefer to use ECoGs recorded by brain surface electrodes for BMI to achieve a high performance.

Eighteen subjects have participated in our clinical studies to date. All of the subjects were recruited from patients, whom we temporarily had to place brain surface electrodes, to treat intractable pain or intractable epilepsy. Informed consent was obtained from all of the patients. All studies were performed with the approval of the ethics committee of Osaka University Medical Hospital.

1.3 Neural Decoding Using Electrodes within Brain Grooves

Most of the primary motor cortex, which is responsible for the final output portion of motor commands, lies within the

anterior wall of the central sulcus. Therefore if we can directly extract the brain signals from the central sulcus, it may be an optimal target for neural decoding of motor function. To demonstrate this hypothesis, we investigated ECoGs recorded from the brain surface electrodes inserted within the central sulcus during two or three types of simple motor tasks of the hand or the arm, such as grasping, pinching, and elbow flexion. We predicted the type of movement based on analysis of single trial ECoGs using a support vector machine (SVM) algorithm. As a result, we were able to predict movement types on a single trial basis with an accuracy rate of 70–90%. Specifically, we first demonstrated that ECoGs from the anterior wall of the central sulcus (the groove in the brain where most of the primary motor cortex lies) are useful for the accurate and early decoding of the movement types [3]. We consider that the extraction of appropriate neurophysiological features from the central sulcus contributed to the accuracy of our movement decoding.

1.4 Real Time Robot Control Using a Wired BMI System

We applied the above-mentioned decoding method using SVM to an ECoG based BMI system for the real time control of a robot arm. We also introduced successive SVM decoding every 200 ms. ECoGs were measured using a clinical 128-channel digital EEG system (EEG 2000; Nihon Koden Corporation, Tokyo, Japan) and digitized at a sampling rate of 1000 Hz. The robot arm was an experimental anthropomorphic hand developed by Prof. Yokoi [4]. As a result, we succeeded in the voluntary control of the grasping and releasing of objects [5]. Using a successive decoding and control algorithm, smooth robot-hand movement was achieved even though the decoding accuracy on a single trial basis was approximately 70%.

1.5 Necessity for a Fully-Implantable Wireless System

Wired leads which penetrate the skin pose a high risk of infection. It is necessary to fully implant a recording system within the body, in order to reduce infection risk through penetrating wire leads. For this reason, we are in the process of developing a fully-implantable ECoG recording system. Integrating this wireless system into the above-mentioned real time BMI system, we ultimately aim to develop a Wireless Human ECoG-based Real-time BMI System (**WHERBS**).

In this paper, we describe the development of the first prototype of our fully-implantable wireless system for human brain-machine interfaces using brain surface electrodes.

2. System Overview

Figure 2 shows a schematic diagram of our fully-implantable wireless system. Figure 3 shows the first prototype. This fully-implantable system includes many new

technologies such as two 64-channel integrated analog amplifier chips, a Bluetooth wireless data transfer circuit, a wirelessly rechargeable battery, 3 dimensional tissue conformable high density electrodes, a titanium head casing, and a fluorine polymer body casing.

The implantable system consists of two parts. One is a

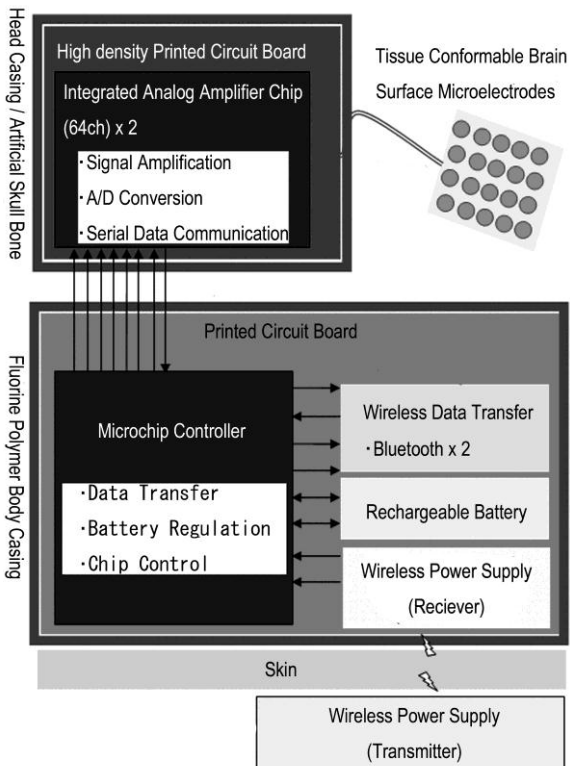
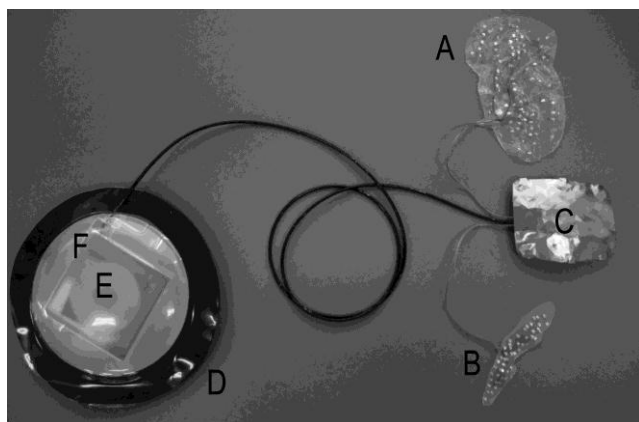

Fig. 2 Schematic diagram of the fully-implantable wireless system.



- A. Brain surface microelectrodes conformable to the outer surface of the individual brain.
- B. Brain surface microelectrodes conformable to the brain groove.
- C. A titanium head casing / artificial skull bone.
- D. A fluorine polymer body casing.
- E. A wireless rechargeable unit, F. A wireless data transfer unit

Fig. 3 The first prototype of the fully-implantable wireless system for the W-HERBS.

head part and the other is a body part. The head part consists of tissue conformable brain surface micro-electrodes, a titanium head casing working as an artificial skull bone also, and a 128-ch integrated analog amplifier unit in it. The body part consists of a wireless data transfer unit and a microchip data controller, a wireless rechargeable unit, and a fluorine polymer body casing.

3. Integrated Analog Amplifier Unit

ECoG is characterized as the signals with low frequency bands from 0.1 Hz to 500 Hz and small amplitudes from 1 μ V to 1 mV (Fig. 4 A). It is necessary to reduce the input-referred noise of amplifier to record it [6]. Variable bandwidth and wide dynamic ranges are also important, because commercial AC noises with similar frequency bands easily contaminate ECoG signals. Thus, a high-linearity low noise amplifier with a variable bandwidth was developed to cover the frequency bands and voltage gains appropriate for recording ECoG signals [7]. The low noise amplifier with 0.1 Hz roll-off frequency is implemented with core differential amplifiers using large size MOSFETs and capacitor feedback scheme biased by ultrahigh resistors of cascade 12 MOSFETs (Fig. 4 B). A VLSI chip was fabricated using CMOS 0.18 μ m process technology in the chip fabrication program of VLSI Design and Education Center (VDEC), the University of Tokyo.

Specifications of the chip functions are as follows.

- channel numbers: 64 channels
- 12 bits A/D converter

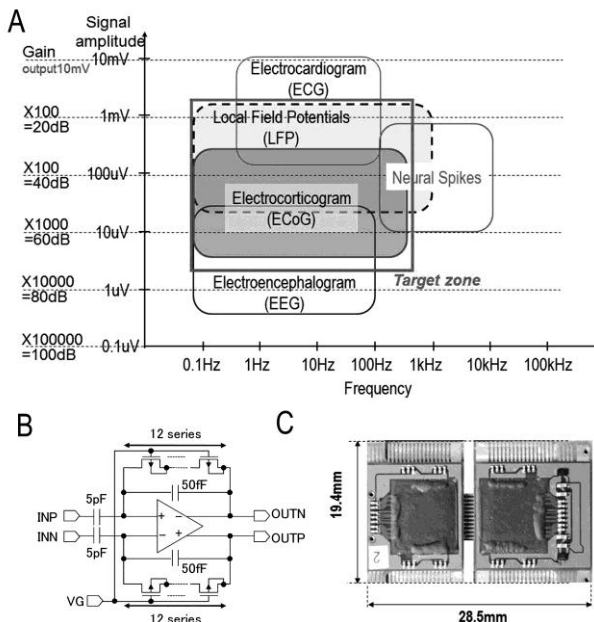

- A: Target frequency bands and gains to cover ECoG signals and local field potentials (LFP).
- B: A circuit schematic of low-noise amplifier.
- C: A 128-channel integrated analog amplifier board

Fig. 4 Integrated analog amplifier.

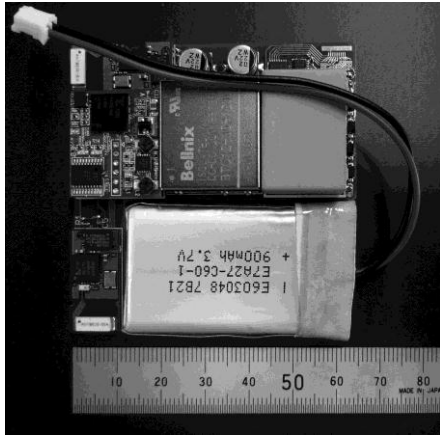

Fig. 5 Wireless data transfer unit.

- voltage gain: 40–80 dB
- signal frequency bands: 0.1–1000 Hz
- input referred noise: $2.8 \mu\text{V}$
- power consumption: 4.9 mW
- chip size: 5.0 mm \times 5.0 mm
- master/slave function for a 128-channel system

A 128 channel analog amplifier board consists of two chips mounted on two high-density printed boards bridged by flexible printed wiring (Fig. 4 C). The size is 20 mm \times 30 mm \times 2.5 mm, which is small enough to be placed within a head casing described in Sect. 7.

4. Wireless Data Transfer Unit

We adapted the Bluetooth protocol communication (Class 2) for the first prototype for high usability. A combination of 2 sets of Bluetooth circuits enabled us to achieve effective data transmission rates of 400 kbps, which allows the transfer of 128-ch \times 12-bit ECoG data in real time. Power consumption is approximately 300 mW, which means that most of the whole systems power is consumed by the wireless data transfer. Further improvements in the data transfer protocol should be made to achieve faster and less power consuming operation of the system. The size is 60 mm \times 60 mm \times 8 mm, which also needs to be reduced (Fig. 5). One of the solution is to change data transfer protocol from Bluetooth to WLAN or UWB.

5. Wireless Rechargeable Unit

The wireless battery charging system consists of two parts. One is a transmitter outside of the human body, and the other is a receiver inside of the human body. We achieved a wireless charging power of 4 W at a distance of 38 mm, which is sufficient to work the whole implantable system (Fig. 6). The coil size of the abdominal part is 40 mm in diameter and 8 mm in thickness, which may be scaled down, if the power consumption is reduced.

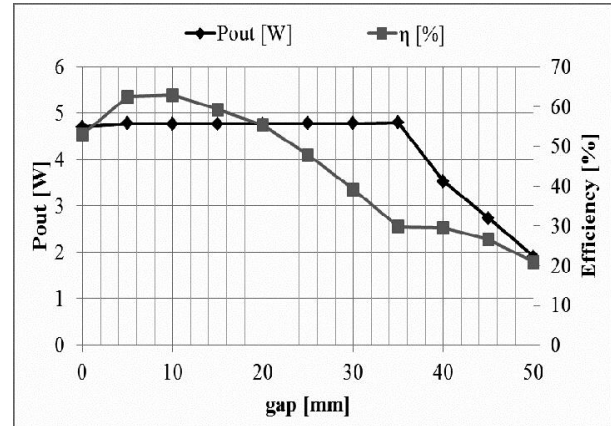

Fig. 6 Relationship between gap and power/efficacy of the wireless rechargeable unit. η indicates % proportion of output to input in the free space.

6. Tissue Conformable Brain Surface Microelectrodes

In order to record ECoGs with higher spatiotemporal resolution, we developed 3 dimensional high density grid electrodes, which fit to an individual's brain surface [8]. We extracted 3 dimensional surface data of the brain surface and the brain groove from the patient's individual MR images. An automatic brain groove extraction software (Brain VISA, <http://brainvisa.info/>) was used. Then we designed male and female molds for the grid electrodes using 3D CAD software (3 matic, Materialize Japan, Tokyo) (Fig. 7). The molds were then rapidly produced by a 3D printer. Silicon sheets fitting the brain surface were made with these molds. The location of each platinum electrode (1.0 mm in diameter) was designed with 3D CAD, taking account of the individual's anatomical information. Inter-electrode spacing was up to 2.5 mm. Regarding brain groove grid electrodes, electrodes can be located on both sides of the electrode sheet. These 3D grid electrodes fit to the brain surface with only minimal compression of the brain tissue, and with high ECoGs yields due to their close contact with the brain surface.

7. Head Casing and Artificial Skull Bone

We developed a head casing made of titanium, which contains a 128 ch amplifier unit. This casing works as a head casing as well as an artificial skull bone, cut to fit a patient's individual skull bone shape using 3D CAD (3 matic) and 3D CAM (Gibbs CAM, Gibbs and Associates, USA) softwares (Fig. 8) [9]. This head casing not only has cosmetic advantages, but it is also safer because other convex shapes pose a higher risk of cutaneous fistula.

8. Fluorine Polymer Body Casing

Compared to a head casing, a body casing offers larger space and does not require careful cosmetic consideration. We

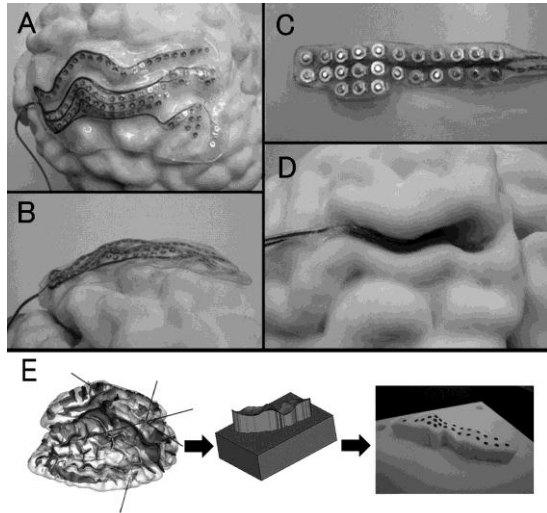

Tissue conformable brain surface microelectrodes fit individual brain surfaces. A, B: Gyral (brain surface) electrodes. C, D: Sulcal (brain groove) electrodes. E: Mold designed with 3D CAD software after automatic sulcal detection.

Fig. 7 Tissue conformable brain surface microelectrodes.

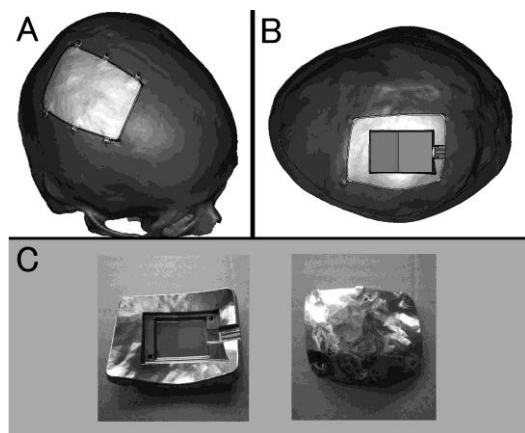

A, B: Head casing designed using 3D CAD software. Three dimensional skull bone data were obtained from individual's CT images. A: Outer side view. B: Inner side view. The head casing contains two 64-channel integrated amplifier chips on a small mounting board which are mounted on a folded inner panel as indicated in a gray color. C: A prototype casing. Left: inner side view. Right: outer side view.

Fig. 8 A titanium head casing/artificial skull bone.

introduced a soft casing made of fluorine polymer, which has advantages in terms of cost, chemical stability, durability, as well as biocompatibility. This body casing embeds a wireless data transfer unit and a microchip data controller, a wireless power supply unit and a rechargeable battery in silicone covered by fluorine polymer films.

9. Concluding Remarks

We have developed the first prototype of a fully-implantable

wireless system. A fully-implantable wireless system is indispensable for the clinical application of invasive BMI to reduce the risk of infection. Sufficient bench testing and animal experiments are necessary in advance to the clinical situation.

BMI is a typical application where advanced methods for telecommunication are required. The telecommunication should be highly reliable to meet the demands of BMI used for medical devices. Also, it should operate with minimal delay, should transmit a plenty of data, should have high tissue permeability, and should be small enough to be implanted. A high-speed digital data transfer protocol with high tissue permeability meets our needs. A high band UWB chip is one of the candidates. There are great expectations for the progress of medical telecommunication.

Acknowledgments

This work was supported by the Strategic Research Program for Brain Sciences of MEXT. We would like to acknowledge Atsushi Iwata (A-R-Tec Corp), Shinichi Morikawa, Yoshihiro Watanabe (Unique Medical), Naohiro Hayaishi (Keisuugiken Corp), Shinichi Yoshimura, Shuhei Kosaka (Aska Electric Co Ltd), and Hirofumi Itoh (Junkosha Inc) for prototype manufacturing of our implantable system, and also thanks to VLSI Design and Education Center (VDEC), the University of Tokyo for the offer of chip fabrication program.

References

- [1] J.R. Wolpaw, N. Birbaumer, D.J. Mcfarland, G. Pfurtscheller, and T.M. Vaughan, "Brain-computer interfaces for communication and control," *Clin Neurophysiol*, vol.113, no.6, pp.767-791, June 2002.
- [2] Z.C. Chao, Y. Nagasaka, and N. Fujii, "Long-term asynchronous decoding of arm motion using electrocorticographic signals in monkeys," *Front Neuroengineering*, vol.3, p.3, 2010.
- [3] T. Yanagisawa, M. Hirata, Y. Saitoh, A. Kato, D. Shibuya, Y. Kamitani, and T. Yoshimine, "Neural decoding using gyral and intrasulcal electrocorticograms," *Neuroimage*, vol.45, no.4, pp.1099-1106, May 2009.
- [4] H. Yokoi, K. Kita, and T. Nakamura, "Mutually adaptable EMG devices for prosthetic hand," *The International Journal of Factory Automation, Robotics and Soft Computing*, pp.74-83, 2009.
- [5] T. Yanagisawa, M. Hirata, Y. Saitoh, T. Goto, H. Kishima, R. Fukuma, H. Yokoi, Y. Kamitani, and T. Yoshimine, "Real-time control of a prosthetic hand using human electrocorticograms," *J Neurosurg*, vol.114, no.6, pp.1715-1722, 2011.
- [6] T. Yoshida, Y. Masui, R. Eki, A. Iwata, Y.M., and K. Uematsu, "A neural recording amplifier with low-frequency noise suppression," *IEICE Trans. Electron.*, vol.E93-C, no.6, pp.849-854, June 2010.
- [7] T. Yoshida, K. Sueishi, A. Iwata, K. Matsushita, M. Hirata, and T. Suzuki, "A high-linearity low-noise amplifier with variable bandwidth for neural recording systems," *Jpn. J. Appl. Phys.*, vol.50, no.4, p.04DE07, 2011.
- [8] M. Hirata, T. Yoshimine, Y. Saitoh, T. Yanagisawa, T. Goto, Y. Watanabe, and T. Saito, Osaka University, Intracranial electrode and method for producing same. US patent application, 12/378,695, 2009/2/18.
- [9] M. Hirata, T. Yoshimine, K. Matsushita, T. Goto, T. Yanagisawa, T. Suzuki, and S. Yoshimoto, Osaka University et al, PCT patent application, PCT/JP2011/001402, 2011/3/10.



Masayuki Hirata (B.S., M.S. and M.D. and Ph.D.) graduated from Faculty of Engineering, The University of Tokyo in 1985 and Osaka University Medical School in 1994. Board-certified neurosurgeon specialized in functional neurosurgery. He was promoted to a Specially-Appointed Associate Professor, Dept. of Neurosurgery, Osaka University Medical School serving as a leader of neural engineering group.

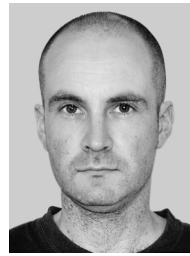

Shayne Morris received an MBA from Yokohama National University in 1994. Following this he received an M.D. degree in Medicine from Osaka University in 2002, and is presently in a Ph.D. course at Osaka University, studying functional neuro-surgery in Osaka University Graduate School of Medicine.



Kojiro Matsushita (B.S., Ph.D.) graduated from Dept. of Engineering, Tokyo University of Science in 2000, a research fellow in Dept. of Informatics, Univ. of Zurich in 2001–2002, graduate student in Dept. of Informatics, the Univ. of Sussex in 2003–2004, graduated from Graduate School of Engineering, The Univ. of Tokyo in 2007, and a postdoctoral fellow in Computer Science and Artificial Intelligence Laboratory, MIT, in 2008. He was recruited as a Specially-Appointed Assistant Professor, Department of

Neurosurgery, Osaka University Medical School in 2009.



Takufumi Yanagisawa (M.D., Ph.D.) graduated from Dept. of Physics, Waseda University and Osaka University Medical School in 2005. Board-certified neurosurgeon. He learned decoding of brain signals under Kamitani Labo at ATR Computational Neuroscience Laboratories. He is currently appointed as a Specially-Appointed Researcher, Dept. of Neurosurgery, Osaka University Medical School with a principal interest in decoding of electrocorticogram.



Takafumi Suzuki received B.E., M.E. and Ph.D. degrees in Engineering from the University of Tokyo in 1993, 1995 and 1998, respectively. From 1998 to 2002, he was a research associate at the University of Tokyo. He is currently an assistant professor at Graduate School of Information science and technology, the University of Tokyo.



Tetsu Goto (M.D., Ph.D.) graduated from Osaka University Medical School in 2002. Board-certified neurosurgeon, currently Assistant Professor, Department of Neurosurgery, Osaka University Medical School and Division of Health Sciences. He is specialized in the analysis of motor and language signals recorded with magneto-encephalography and electrocorticography.



Takeshi Yoshida received B.E., M.E. and Ph.D. degrees in engineering from Hiroshima University in 1994, 1996 and 2004, respectively. From 1996 to 2001, he was with System Electronics Laboratories, Nippon Telegraph and Telephone Corporation. He is currently an assistant professor at Graduate School of Advanced Sciences of Matter, Hiroshima University.



is appointed as Research Supervisor of JST, Decoding and Controlling Brain Information.

Mitsuo Kawato (B.S., M.E., Ph.D.) graduated from Faculty of Physics, The University of Tokyo in 1976 and Dept. of Biophysical Engineering, Osaka University in 1978. He has been a faculty member at Osaka University in 1981–1988, recruited to ATR, in 1988, currently serving as Director, ATR Brain Information Communication Research Laboratory Group since 2010. He is acknowledged as a pioneer in computational neuroscience including internal models in the cerebellum and robot learning. He



Fumihiko Sato received B.S. and Ph.D. degrees in Engineering from Tohoku Gakuin University in 1995 and 2000, respectively. From 2000 to 2006, he was an assistant professor at Tohoku University. He is currently an associate professor of Dept. of Electric Engineering, Tohoku University.



University Medical School and Director, Medical Center for Translational Research, Osaka University Hospital.

Toshiki Yoshimine (M.D., Ph.D.) graduated from Osaka University Medical School in 1975. Board-certified neurosurgeon, specialized in brain tumor and epilepsy surgery. He is a Director, Japan Neurosurgical Society, and Neurotrauma Committee Member, World Federation of Neurosurgical Societies (WFNS). He has been a research fellow in Mayo Clinic in 1980–1983, a visiting professor in University of Mainz in 1995. He currently serves as Professor and Chairman, Dept. of Neurosurgery, Osaka